

Photoelectric sensors with special function

3.1	Area sensors	133
3.2	Surface sensors	153
3.3	Contrast scanners	159
3.4	Luminescence scanners	165

Area sensors

	Glossary of technical terms	134
AX80 serie	High resolution area sensors - DC	140
AX100 serie	Medium resolution area sensors - DC	144
AX500 serie	Area sensors with parallel/analogic outputs - DC	148

Introduction

Optoelectronic scanners are not covered by the provisions of EN 60947-5-2, Sept. 95 and the following details only refer to common parameters.

The technical terms of the paragraph headings reflect those used in the wording of this legislation, whilst those in italics are synonyms.

The specifications listed relate to the nominal performance envisaged by said legislation and apply to products whose technical specifications do not include a specific figure.

Operating principle

Type-T Optoelectronic scanners are made up of two elements; an emitter and a receiver. The emitter has an optical unit that consists of an array of photoemitters which emit a series of narrow luminous pulses to the receiver in a consecutive well-defined manner.

Luminous radiation is generated by a solid-state source made up of high-performance long-lasting semiconductor elements. This radiation can be from outside the visible band.

The receiver has an optical unit which is made up of an array of photoreceivers which correspond geometrically to those of the emitter.

The luminous radiation reaching the photoreceivers is converted to an electric signal, amplified and processed in order to drive receiver output elements. As there is synchronous reading of the luminous pulse, a synchronous signal must be transmitted between emitter/receiver. Detection occurs when the path of the beam is interrupted by the presence of an opaque object.

Parallel-ray scanning

Every pulse emitted by a single element of the emitter array must be synchronously read by the corresponding element of the receiver array so that the single pair can be considered in light state. Every single emitter/receiver pair only controls its own axis of conjunction. Scanning determines an area crossed by parallel rays.

Using parallel rays enables precise information to be obtained regarding size and position of target object.

Cross-ray scanning

Every pulse emitted by a single element of the emitter array must be synchronously read by the corresponding element of the receiver array, and by a variable number of other receivers positioned on either side of the central one, so that the single pair can be considered in light state (i.e. path of beam completely clear). Every single emitter/receiver pair controls a range of axes which originate from the emitter and reach an array of receivers. Scanning determines an area crossed by cross rays in a complex manner.

The number of lateral receivers involved in reading the single emitter varies according to the range of the particular model. Every emitter must illuminate various receivers and can only do so if the optical-beam angle is sufficient for a certain distance. The number of receivers enabled can also vary during scanning. In extreme cases the two emitters on the edge of the array may only illuminate the internal lateral receivers because the external ones do not exist. Another case in particular is when single emitters must always illuminate all the receivers. This operating mode is simple to manage but requires large beam angles.

Operating with cross rays does not enable precise information to be immediately obtained regarding size and position of target object, but merely reveals its presence.

Synchronising scanning

It is the function which allows a single element of the receiver array to be enabled to read only at the moment in which the luminous pulse is sent by the corresponding emitter element.

The synchronisation serves to determine a strict relationship between corresponding emitter and receiver so as to reduce the effects of interference from other signals.

With type T parallel-ray scanning sensors used for determining size and position of objects, the synchronisation must be realised by connecting a cable between emitter and receiver.

With sensors that are only used for detecting the presence of an object, the synchronisation can be sent optically. Usually an emitter is added to the receiver array sends synchronisation message to an additional receiver in the emitter array. Alternatively, timing techniques can be used for autosynchronisation of the receiver, thus eliminating the need for cabling between emitter and receiver.

Devices also exist whose arrays of optical elements alternate between emitters and receivers that pass the optical pulses on to each other. This type of solution is another which does not require cable synchronisation and cannot be used for pinpointing position and size of objects.

State of area

To define the state of the area or the single elements, reference must be made to the **light/dark** condition of the receivers. The **dark** condition is determined by the presence of an opaque object that blocks the path of the rays. The **light** condition is on the other hand determined by the fact that the path between emitter and receiver is clear.

Output operating logic

Area function output

An output whose logic state is a function of the state of the area.

OR function: The output represents the OR function indicating dark state of the single E/R pairs.

If just one single pair is obscured, the dark state will be assumed by the output.

It is necessary that all the pairs are in light state before the output will assume light state.

AND function: The output represents the AND function indicating dark state of the single E/R pairs.

It is necessary that all the pairs are in dark state before the output will assume dark state.

If just one single pair is in light state, the light state will be assumed by the output.

• Array outputs (parallel)

A group of outputs that indicate the light or dark state of the single elements of the receiver array.

Independent action

Switching of output status does not depend on the approach speed of the target and there are no transition stages between ON and OFF. All barrier outputs which provide a logic level are of this type unlike analogue outputs which are not.

Standard target

With type T scanning sensors, the standard target does not correspond to the target which will in practice be detected but is instead the emitter element.

Excess gain (Eg)

Indicates the ratio between the signal obtained at a specific distance and that

necessary to trigger the device (see also "Excess-gain graph"). Although switching of receiver ON/OFF state always occurs at Eg levels close to 1, technical specifications relating to S parameter refer to $Eg=1.5$. In this case S is intended as the distance between the two elements at which there is a guaranteed signal operating margin equal to 1.5.

Operating distance (S)

Generally used to indicate the operating distance between the two elements of the system, the emitter and receiver units in the case of type T models, and between single unit and reflector for type R. Unless otherwise stated, it is expressed for $Eg=1.5$.

Optical axis spacing (BS)

Indicates the distance that exists between the optical axes of the single elements of an array and is necessary for defining resolution and height of control area.

Diameter of optical lens (BD)

Indicates the diameter of the optical lens of a single array element and corresponds to the diameter of the optical beam in the proximity of the unit itself. It is necessary for defining resolution.

Number of optical elements (BN)

Number of elements making up the array. It is used for defining height of control area.

Height of area (AH)

Indicates the height of area selected for the path of the optical rays that are transmitted to the receiver by the emitter; the formula is:

$$A_H = [B_S \times (B_N - 1)] + B_D$$

Blind zone

Using cross-ray scanning makes it possible to obtain a reduction to 1/2 the vertical spacing between two contiguous rays. With this technique a reduction of the minimum detectable diameter is obtained. This does not however occur in a uniform manner over the whole control area. In the zones close to the sensor where the spacing of the rays remains equal to that of the optical unit, the minimum diameter of a detectable object remains the same as it would have been if there were no cross rays. This is not a blind zone but only less fine resolution. The amplitude of this zone is equal to 15% of the distance between E and R.

Resolution

Indicates the minimum dimensions (diameter) of the test target that it is possible to continually detect whilst moving the target vertically in the control area (the test object is a cylindrical bar of opaque material).

In applications where it is necessary to guarantee with complete certainty that a particular diameter will be detected within the whole area between emitter and receiver, the resolution must be set according to the mechanical dimensions of the optical unit. In type-T sensors the resolution corresponds to the diameter that will always guarantee that at least one optical beam is interrupted. This is equal to the optical element spacing plus the diameter of the single optical lens.

In detect-and-count applications the resolution can be defined with much less restrictions. Using the sensitivity control to reduce excess gain, it is possible to set the resolution at just the optical element spacing. Use of the cross-ray function can improve the resolution still further to 1/2 the spacing of the optical elements (this only applies to the

centre of the control area and not near to the optical units; see blind zone).

The cross ray function can detect fine objects, although they must be a certain width with a resolution which is effectively zero. The minimum width for this resolution depends on the inclination of the cross rays.

Rated operating distance (Sn) *Nominal sensing distance*

Conventional value of operating distance S for photoelectric switches without sensitivity adjustment. If there is a sensitivity adjuster, it is intended as being with adjustment at maximum.

This conventional value is a figure which refers to this series and does not consider manufacturing tolerance ($\pm 10\%$) and variations that can be produced by differently rated supply voltages and temperature outside the range $23\pm 5^\circ\text{C}$.

Sensing range (Sd)

Range within which the operating distance relative to the approach/withdrawal of standard target (emitter or reflector) can be regulated if the sensor is fitted with a sensitivity adjuster. The maximum value of Sd has the same definition as Sn (see above). If minimum value of Sd is not quoted it should be taken as being equal to 0. If it is given however, tolerance is not guaranteed that of Sn.

Effective operating distance (Sr)

Is the operating distance S assumed by a specific relative to the approach of standard target in nominal conditions of power supply voltage and ambient temperature ($23\pm 5^\circ\text{C}$). It is expressed as a percentage of Sn. This is effectively the manufacturing tolerance.

Type-T scanning barriers have guarantee of Sr within range 90% -200% of Sn with $E_g=1.5$.

Usable operating distance (Su)

Is the operating distance relative to the approach of standard target calculated with power supply voltage at between 85 and 110% of nominal value and a specified ambient temperature. The manufacturer guarantees that it is between 90 and 110% of Sr. Minimum Su is however guaranteed as being $\geq 81\%$ of Sn.

The user should consider this as the working range which is at all times guaranteed in the whole range of environmental working conditions specified.

Differential travel (H)

This is given as a percentage of Sr and expresses as an absolute value the maximum difference between the switching points during the target's approach and departure from the operating face.

The difference between the two switching distances is purposely introduced to guarantee the constant state of the output should the object come to be found inside the switching points. Unless otherwise indicated, $0.02S \leq H \leq 0.2Sr$.

H can be influenced by the thermal drift, but the value specified remains inside that declared in the ambient temperature range. It should be noted that in type-T sensors the target object crosses the optical beams perpendicularly and therefore the hysteresis quoted as above bears no direct relation to what actually happens in practice.

Rated operational voltage (Ue)

Expresses the supply voltage range. The manufacturer guarantees that the barrier will function correctly in a voltage range between 0.85 Ue min. and 1.1 Ue max. (see Ub).

Voltage rating (UB)

Operating voltage

Expresses the power supply voltage range between minimum and absolute maximum values.

Ripple

Amplitude of maximum acceptable ripple in the DC power supply voltage expressed as a percentage of the average value of the latter. Correct operation is guaranteed with ripple $< 10\%$ Ue. In actual fact many sensors operate perfectly well even when the ripple is much higher.

Voltage drop (Ud)

Indicates maximum value of drop across the active output, with rated load current (Ie), power supply voltage within UB range and temperature $23\pm 5^\circ\text{C}$. Unless otherwise stated the manufacturer guarantees the following for dc models:

$U_d \leq 3.5V$ (3-wire models)

Rated insulation voltage (Ui)

Unless otherwise stated, sensors up to 50 Vac and 75 Vdc are tested to 500V ac.

Impulse voltage withstandability (Uimp)

Unless otherwise indicated, the supply terminals and output leads of dc units are tested with a pulse amplitude of 1KV. The specifications are as follows: 1.2/50 μ s, 0.5J, generator impedance 500 Ω .

No-load supply current (Io)

The current drawn by the sensor from its supply when not connected to a load. Specifications include Iomax which indicates the maximum current drawn within the voltage range Ue.

Rated operational current (Ie)

Load current

Is the current drawn by the load. The tables quote the Iemin indicating that guaranteed in worst possible operating conditions.

Minimum operational current (Im)

The current which is necessary to maintain ON-state conduction of the switching element within the supply voltage range Ue.

OFF-state current (Ir)

Leakage current

The current which flows through the load circuit in the OFF-state at the maximum supply voltage (UBmax).

The load value is specified in such a way that at UBmax the load itself can be bridged by a current equal to Ie. The user must ensure that the Ir current is below that required to hold load in ON-state or this could result in the load remaining connected even if in OFF-state. With parallel connection of sensors the Irs need to be added together.

Utilisation categories

Unless otherwise indicated, output utilisation categories are as follows:

Category DC-13; relay driver dedicated outputs.

Category DC-12; logic-input-driver dedicated outputs

Switching element function

The functions can be expressed as follows:

- by indicating the state of the receiver with reference to ON/OFF state; or
- indicating ON/OFF state with reference to the presence of the target

1a) Dark operate. Function that allows current to flow when the path of the luminous beams is interrupted and will prevent flow when the path of the luminous beams is not

interrupted.

2a) Light operate. Function that allows current to flow when the path of the luminous beams is not interrupted and will prevent flow when the path of the luminous beams is interrupted.

1b) Make (NO normally open). A make function causes load current to flow when a target is detected and not to flow when a target is not detected.

2b) Break (NC normally closed). A break function causes load current to flow when a target is detected and not to flow when a target is not detected.

Make-break or changeover function

A switching element combination which contains one make function and one break function.

Type of output and load connection

NPN: The switching element is connected between output and negative terminal. When in ON-state the current is drawn from load across the output terminal. The other load terminal is connected to the positive terminal of the power supply.

PNP: The switching element is connected between output and positive terminal. When in ON-state the current is drawn from positive pole and supplied to the load across the output terminal. The other load terminal is connected to the negative terminal of the power supply.

Open collector: The output transistor is not internally connected to a pull-up or pull-down load. Therefore it is possible to connect an external load supplied by an external voltage. If the output is not the open-collector type, it is possible for the load to be supplied by an external voltage using a blocking diode in series to the output.

This solution increments the output voltage drop.

.Analogue: Analogue outputs make available a signal whose amplitude is directly proportional to the sensor area status, i.e. number of optical element in light or dark state. The output will have a quantized signal. Two types of analogue output are available; a current-type with rating 4-20mA, and a voltage-type rated 0-10V.

The analogue outputs can increase or decrease their values according to size of area and setting chosen which can be either NO (dark operate) or NC (light operate).

The minimum amplitude of step variation will be a function of the number of optical elements present. The usual value of the output parameter will be:

V output (Volt) = $(10/Bn) \times$ (No. of optical elements occupied if NO or free if NC)

I output (mA) = $((16/Bn) \times$ (No. of optical elements occupied if NO or free if NC)) $+4$

For example with 8 optical elements:

V output = $1.25 \times$ (No. of optical elements occupied if NO or free if NC) V

I output = $4 + (2 \times$ (No. of optical elements occupied if NO or free if NC) mA.

The return of external analogue loads connected to analogue outputs must be to the negative pole.

An analogue voltage output has a current rating of 10mA, therefore the minimum resistive value that can be applied as load corresponds to a 1K Ω resistor. The output has overload and short circuit protection with an intervention threshold of 25mA.

Maximum voltage that can be delivered by analogue current output is 11V. Maximum resistive value applicable is 500 Ω .

Short circuit protection

All outputs of category DC-13 are usually supplied with integrated short-circuit protection, whilst category DC-12 devices do

not have integrated protection. Output protection of dc sensors in the case of short circuit or overcurrent is effected by establishing a maximum current threshold (limiting current). When this threshold is exceeded (usually between 1.5 and 3 times I_e), the sensor opens the output circuit. Normal operation is resumed by following certain procedures which vary according to type of protection:

a) autoreset: reset occurs automatically straight after the cause of the short circuit has been removed

b) with hold: to restore normal operation it is necessary to effect a switching exercise or switch off power supply and remove cause of short circuit.

In both cases, during the short circuit a) one or b) a burst of current pulses (whose amplitude can reach 5A) will flow across the output.

Polarity-reversal protection

No damage will occur to sensor if the supply wires are reversed.

Overvoltage protection

When the UB voltage is exceeded for a few moments, sensors will not generally be damaged provided dissipated energy does not exceed 0.5J (see also Uimp).

Inductive-load protection

Unless otherwise stated, dc sensors are fitted with an inductive-load (surge) protection which consists of a diode or Zener diode. See section "electrical connections" for maximum L value.

Time delay before availability (tv)

This is the time between the switching on of the supply voltage and the instant at which the sensor becomes ready to operate correctly. During this phase the output circuit remains in OFF-state; false signals may be present for a maximum of 2ms. This time is necessary for preventing that when switching on the sensor output find itself in an undefined state and that there may be false operating cycles present capable of exciting the load. Unless otherwise stated the delay is ≤ 300 ms.

Switching frequency (f)

This is the maximum output switching frequency performed by the output circuit and is stated as:

$$f = \frac{1}{t_{on} + t_{off}}$$

For ac sensors, the minimum output pulse width must not fall below half sine period. Alternatively, t_{on} and t_{off} may be supplied instead of f .

Turn on time (ton)

This information is not usually quoted. It is used along with t_{off} to calculate f . The time indicated represents that required to switch output to light state with respect to the instant in which the receiver element has effectively switched to this same state.

Turn off time (toff)

This information is not usually quoted. It is used along with t_{on} to calculate f . The time indicated represents that required to switch output to dark state with respect to the instant in which the receiver element has effectively switched to this same state.

Status indicators (LED)

The LED indicators can be classified according to colour:

CONTINUOUS GREEN: Power on

CONTINUOUS YELLOW: Output on
CONTINUOUS RED: Fault.

Synchronisation output

Receiver output that must be connected to the corresponding emitter. Digital information regarding synchronisation of reading and state of area can be transmitted.

Alarm output

It is an output supplied on some models that remains in ON-state during normal conditions and switches to OFF-state should an alarm be triggered.

It is possible to add a self-checking pulse.

Alarms

• Low signal alarm

This is defined by checking the signal level received. A check is made on every element of the ratio between signal and two standard thresholds S_c and S_a .

S_c is defined as the trigger threshold and is used to determine if state is light or dark.

S_a is defined as the margin threshold and is used to determine that there is adequate signal margin.

If the sensor is in dark state, or if it is light state and all array receivers have a margin superior to S_a , the alarm output is in ON state.

If the sensor is in light state and not all array receivers have a margin superior to S_a , should this condition continue, the alarm output will switch to OFF.

• Software alarm

Alarm condition caused by the Watchdog function of the receiver microcontroller. In the eventuality that a software fault occurs or there is a stoppage of the quartz oscillator (no clock), the alarm switches to OFF-state.

• Hardware alarm

If the power supply is cut or a short circuit occurs to one of the protected outputs, the alarm switches to OFF-state.

Autocheck

Self-monitoring

Master/Slave models have an autocheck circuit which generates a continuous pulse train obtained as a complement of the actual output state. The pulses have a duration of 200-400 μ s. They are present in both ON and OFF output states and are generated at the end of the scanning cycle. These pulses only decrease the mean value of the output current by about 10%, therefore a standard load continues to operate correctly. Even a normal PLC input is not capable of detecting these pulses.

An external Watchdog circuit or a fast PLC input can be used to detect the presence of the autocheck pulses: their presence means that the sensor works properly and their absence that a failure has occurred.

These same pulses are used as synchronising output in the Master/Slave function.

Check input

It is an input supplied on some models that when disconnected results in the suspension of luminous-pulse emission, without interrupting the other functions. This function can be used to simulate the interruption of all optical paths and allows a user-friendly test to be effected in order to verify that the system is operating correctly. If input is disconnected with sensor in free state, output should switch from light to dark state. If switching does not occur, it indicates a fault in the system.

It can also be used to enable emission at certain moments so as to eliminate problems of interference with other optical devices.

In the sensors selected as Slave it must be

connected to the alarm output of the preceding sensor and performs the function of synchronising input.

NO/NC input

A dedicated input for programming the switching function of the area or array outputs. In some models it is only available as a mechanical switch housed in the device itself.

This input is only read when switching on to effect time delay before availability. NO/NC cannot be modified during normal operation.

Power emission control input

An emitter dedicated-input for programming power emission. It can be used together with the alarm function to verify the available reserve of Eg. With input disconnected, emitted power is reduced by 20%. It is normally in ON-state.

Slave/Master function

A function which can be activated by a switch supplied on some receiver models that have a Master configuration and can be chosen as Slave.

This function is used to create a chain of connected optical scanner-systems in which the single emitter/receiver pairs effect scanning of the area in sequence thus avoiding the possibility of interference between different units. The Master device must be the first in the chain. Its alarm output must be connected to the enable input of the successive Slave device. Any other Slave devices must be cascade connected in the same manner.

The enable input of the Master device transfers the enable function to all the other Slave devices that follow, leaving this control function active along the entire chain. The alarm condition spreads behind the pair that activated it thus making available the signal on the last alarm output of the chain.

The receiver area-outputs that make up the chain can be parallel connected if it is necessary to monitor the state of the entire area. Selecting the NO function (dark pulse) for every sensor will produce the same function for the entire area.

Degree of protection

The minimum required degree of protection for photoelectric sensors is IP54 (partial protection against dust and water jets). In general, the minimum degree of protection offered is IP65 (complete protection against dust and water jets).

Pollution degree

The degree of environmental pollution for intended use is that relating to industrial environments (3), which allows non conductive dry pollution that could become conductive due to condensation. These devices do not usually have exposed electrical components. When connectors or terminal clips are fitted they will be enclosed in a protected microenvironment.

The operating distance of photoelectric sensors can be affected by a dirt being deposited on the optical components.

Ambient temperature range

Temperature range

Temperature swing for scanning sensors is guaranteed from -5 to 55 $^{\circ}$ C. The figures quoted are valid within the declared ambient temperature range. Generally speaking the sensors can be used within a 10 $^{\circ}$ C greater range with only a slight loss of performance. Details regarding thermal drift of currently available sensors for wider temperature ranges are available on request.

Temperature drift

Maximum change in the operating distance within the temperature range expressed as a percentage of the effective value S_r . The manufacturer guarantees that photoelectric sensors have a thermal-drift range of $\pm 10\%$ of S_r .

Relative humidity (RH)

The relative-humidity range within which normal performance is guaranteed. Photoelectric sensors can be affected by a high RH in the form of condensation which could be deposited on the optical surfaces. Some plastic materials can deteriorate if left for long periods in a dry environment ($RH < 10\%$), but even if used, these materials do not form part of the sensors functional components.

Ambient light interference

Interference to external light

Unless otherwise indicated, it is intended that the sensing range S_d remain unaffected when the receiver is illuminated by artificial ambient light from lamps and light bulbs, etc. (3000°K) varying from 0 to 5000 Lux.. This immunity level is not sufficient to exclude the possibility that part of the sensor may be affected by the presence of a strong natural or artificial illumination. It is advisable to keep the receivers away from direct sunlight and positions close to lamps and they should not be placed facing lighting systems. Immunity to high-frequency fluorescent lights is less than that provided against incandescent lighting.

Excess gain graph

This expresses the signal margin with respect to the distance of the standard target. The points at which $E_g > 1$ indicate the distances at which the switch is in light state. Where $E_g < 1$ it is in dark state.

Parallel displacement graph

For model T indicates the maximum displacement between the two parallel axes of the emitter in relation to distance for $E_g = 1$.

Detection range graph

This is prepared when details regarding particular types of targets are required (e.g. small diameters). Indicates the area in which the target is detected.

Angular displacement graph

Expresses maximum angle of displacement for $E_g = 1$ in relation to distance. It can be supplied for both elements. If only one curve is supplied, it is the more critical.

Mutual interference graph

It indicates minimum linear displacement required between the emitter and a receiver of another optical scanner pair in order to have a interference signal lower than hysteresis in relation to distance.

Choosing a sensor

- Choose a optical scanner suited to the working environment: check chemical compatibility between the sensor build materials and any substances present, temperature range, degree of protection against dust and liquids, presence of dust or steam, presence of condensation or ice, vibration, shock, presence of strong natural or artificial light, electromagnetic compatibility, suitability of power supply voltage and type of load. **If necessary consider the possibility of fitting specially-designed accessories.**

- Select an operating distance suited to the dimensions, colour and opaqueness of the

material to be detected.

- Verify that minimum distances have been respected between sensor and other nearby sensors.
- Ensure that the number of operations required does not exceed the frequency of operating cycles. Should signal phase also be important, give careful consideration to **ton and toff**.

Positioning of unit

All sensors must be positioned so as ensure that dust and or liquids do not come into contact with the optical surfaces and thus adversely effect the path of the luminous beams. Mount in a position that protects both optics and body from coming into contact with the target material and ensure that power cables are suitably placed where wear-and-tear and the possibility of breakage are reduced to a minimum. The receiver should not be directly pointed towards sources of artificial or natural light. Always keep sensor away from sources of heat, in particular columns of hot air and radiation emanating from incandescent material.

Installation

The instructions listed below refer to particular conditions of E_g which are as follows:

$E_g = 1$; The signal received is very close to the ON/OFF threshold and the sensor output switches at around this level. The output LED or the load itself will indicate this state.

$E_g = 2$; The signal received is very nearly double the ON/OFF threshold and the sensor output is in light state. If present, it is the signal margin LED that indicates this state. In some models the safety margin is $E_g = 1.5$ but this fact does not alter the significance of this description.

Refer to product specification sheets for a full explanation regarding LED indicators.

Type T with sensitivity adjustment.

It is first of all necessary to choose correctly the type of emitter/receiver combination and operating distance in accordance with type of target material (small or large objects, opaque or semitransparent) and degree of dirt present in the working environment (see E_g curves).

a) With large and completely opaque objects or for detecting holes, it is advisable to maximise signal margin ($E_g > 2$) by keeping the set sensitivity at maximum.

If working environment is dusty it is necessary to operate with ample margins of E_g (3-10) by using distances below S_a .

b) For detecting small objects it is recommended to maintain $E_g = 2$. In this case, the minimum diameter of the target object corresponds to the optical element spacing if cross function is not activated. If smaller diameters need to be detected, weigh up the need for a model with cross-ray function and also consider blind zones. When operating with small signal margins, the working environment should obviously have a degree of cleanliness that will not compromise the stability of the setting.

c) For detecting the presence of fine opaque sheets, the use of a cross-ray model is indispensable. The thickness of the sheet is of little importance is the width is sufficient to block the inclined rays that cross the control area.

d) If the target objects are close to shiny surfaces parallel to the optical axis, it is necessary to consider the possibility that the object may be not detected by the reflection on the shiny surface of the peripheral beams. In this case use models with a narrow beam.

1) Fix the sensor securely but not definitively, if possible using the brackets supplied. Position the two sensor elements so that the optical axes coincide as much as possible.

2) Check that power supply voltage and load are within the prescribed limits and switch on sensor. If the check and power-increase functions are fitted, ensure that the former is disconnected and the latter disconnected.

3) Check that the power supply LEDs are on and the alarm LEDs are off. If this is not the case, check power supply, load and cabling.

4) 6) Set the emitter trimmer to the maximum by turning clockwise. The emitter should be orientated by pointing an edge of the housing towards the receiver.

5) Next go to receiver and orientate towards emitter with the maximum precision seeking to obtain minimum luminosity and the turning off of the E_g LED. If the E_g LED does go out, fix receiver position in the middle of the zone.

6) Go to emitter and repeat precision tuning of orientation as per 5) keeping a watch on the receiver E_g LED.

If the target objects are opaque and of large dimensions, verify that the trimmer is at maximum and definitively fix photoswitch. If on the other hand the objects are small and not completely opaque, continue as follows.

7) Having obtained optimum orientation with $E_g > 2$, turn the trimmer anticlockwise until obtaining $E_g < 2$, and then turn clockwise until obtaining $E_g > 2$. Mark this point as position A. **The position found is that which offers optimum working conditions for detecting presence/absence of small objects or semitransparent materials with equal precision and discreet safety margins.**

8) Place the target object along the optical axis and by moving check that the sensor switches ($E_g < 1$). If this does not occur it means that the target object is too transparent or too small and it will be necessary to operate (environment permitting) with signal margins below 2. In this case, with the object still in position, turn the trimmer anticlockwise until obtaining $E_g < 1$. Memorise this point as position B and position trimmer at an intermediate point between A and B.

Carefully check correct operation under actual working conditions since this position is critical. In conclusion definitively fix photoswitch.

Type T without sensitivity adjustment

1), 2), 3) 4), 5), 6), 7) as above.

Models without sensitivity adjustment are not suitable for detecting objects that require an E_g close to 1 if this cannot be obtained by merely by increasing the operating distance S . In extreme cases, low E_g can be obtained by moving the single pairs out of line. However, this can cause non uniform E_g s for the single elements making it difficult to obtain consistent performance over the whole control area.

Carefully check correct operation under actual working conditions and in conclusion definitively fix sensors.

Electrical connections

- Sensor connection leads should not run close to other power cables.

- The synchronising connection between receiver and emitter should be no longer than 10m.

- If lengthening power supply cables, use ≥ 1 mm cable. For lengths exceeding 100 m, fit a filter capacitor near to the sensor.

- Ensure power supply voltage does not exceed the limits specified by U_b .

If a non-stabilized supply voltage is used, check power supply peak-voltage value with minimum absorption. Also check minimum value and amplitude of ripple at maximum absorption. If the same voltage is also used to switch inductive loads, a suitably-sized suppressor should be installed. Suppressors also offer protection against incorrect connection of the power supply that could prove potentially disastrous for all sensors.

- Always expect the application of a fuse on the feeder, even if regulated power supplies are used.
- Verify compatibility of load with type of sensor output.

The current drawn by the load must not exceed the value I_e but should not be less than I_m . Load excitation voltage must not be less than the minimum supply voltage minus U_d . Load deenergize current must be greater than I_r . When interfacing with logical inputs check compatibility V_{IL} / U_d . Driving a filament lamp could result in the intervention of the dc protection. If necessary arrange to limit the lamp's switch-on current.

When driving dc inductive loads, check that load inductance L (Henry) does not exceed the value indicated in the following formula and that the number of operations with this L value is no more than 6/min (A13 category).

$$L = 2U_e^2 \times 10^{-3}$$

A dc capacitive load must not exceed the rated value if the intervention of the current-limiting circuit is to be avoided. It should be noted that some logic or timer inputs may have an R-C coupling. If the peak current triggers the current-limiting circuit, the problem can be resolved by fitting a 100-300Ω resistor in series at the input.

When using very long connection leads, consider the cable capacitance (150pF/m).

Series/parallel connections

Parallel connection of two or more sensors is achieved by connecting their output terminals to a common load. In this way it is possible to realise OR logic with NO outputs (load is excited even if just one of the sensors is activated) and NAND logic with NC outputs (load is deenergized only if all sensors are activated).

With parallel connection it should be noted that the OFF-state current through the load (the sum of the OFF-state currents of every single sensor) must be less than the deenergize current.

With models that are not the open-collector type, it is recommended that a diode be inserted in series at the output to maintain the independence of the sensor's internal LED.

Series connection of photoelectric barriers is not possible. Parallel series connections can however be created by using a complementary output.

If just two sensors are to be series connected, it is worth using two sensors having different types of output (PNP/NPN) with load connected between them.

Electromagnetic compatibility

Fast transient burst immunity

Our dc and ac sensors all conform to standard EN61000-4-4, 1995. Unless otherwise stated, test level is 2KV with capacitive coupling. Criterion A is adopted for performance analysis during the test.

The device should continue to operate correctly even in the presence of interference by maintaining a minimum performance level. Unless otherwise indicated, minimum performance level is intended as meaning that the device must not be subject to false output signals or that in any event these false signals should have a duration of no more than 1 ms in the case of dc devices and a half wave for ac devices.

All devices are tested in both ON and OFF-state with the signal received at least two times greater than the trigger threshold and at least half the trigger threshold.

Electrostatic discharge immunity

Our dc and ac sensors all conform to standard EN61000-4-2, 1995. Test levels are as follows: 4KV with contact discharge for devices with metal housing, 8KV air gap discharge for plastic housing. Criterion B is adopted for performance analysis during the test.

After the disturbance has finished, the device should function normally without the need for resetting.

Radiated electromagnetic field immunity

All our devices conform to standard ENV50140, 1994. Unless otherwise stated, test levels are as follows:

80MHz - 1GHz 3V/m 80% AM modulation 1KHz sine wave. Criterion A is adopted for performance analysis during the test.

The device should continue to operate correctly even in the presence of interference by maintaining a minimum performance level. Unless otherwise indicated, minimum performance level is intended as meaning that the device must not be subject to false output signals or that in any event these false signals should have a duration of no more than 1 ms in the case of dc devices and a half wave for ac devices. All devices are tested in both ON and OFF-state with the signal received at least two times greater than the trigger threshold and at least half the trigger threshold.

Radiated emission

All our devices conform to standard EN55022 Class B, 1986.

Conducted emission

All our ac devices conform to standard EN55022 Class B, 1986.

Applications

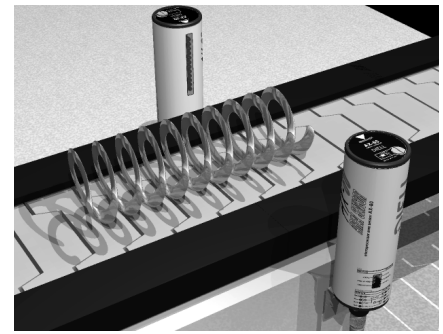

Materials handling: detection of object presence by different and irregular shapes

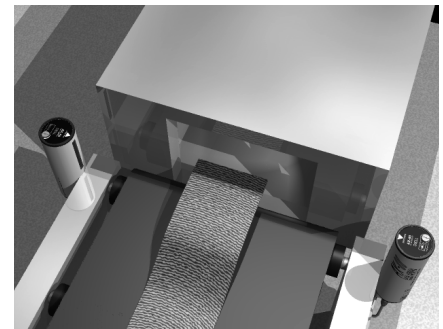

Wood industry: way in of a wood table with irregular profile on painting machinery

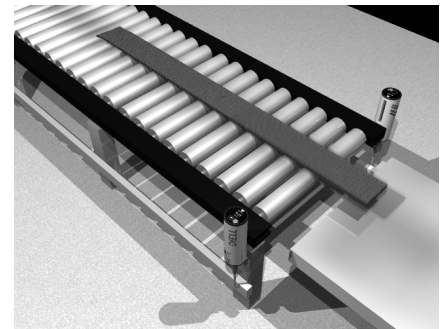

Wood industry: detection of a long board (even by vibrations) coming out from a rolling machine

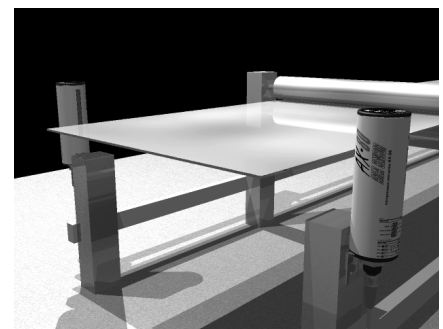

Metal processing: control of sheets coming out from rolling machines (even by vibrations)

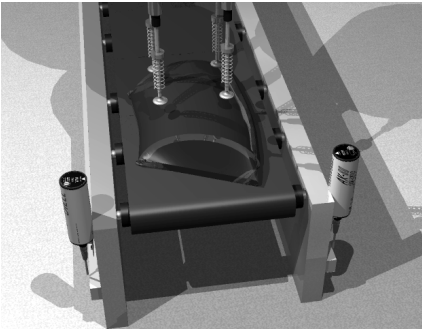

Glass processing: detection of windscreen on conveyor belt

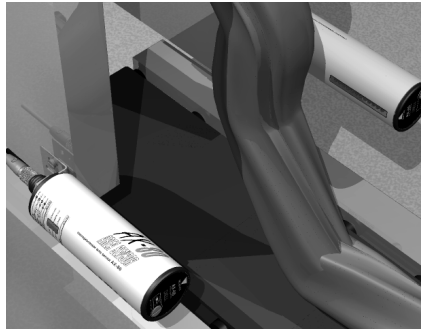

Extrusion machines: control of material presence coming out

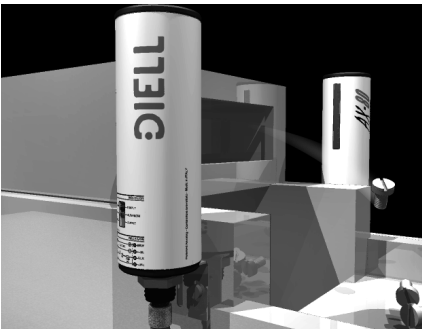

Moulding: control of pieces released by moulding machines



Handling automations: presence detection and object positioning on conveyors

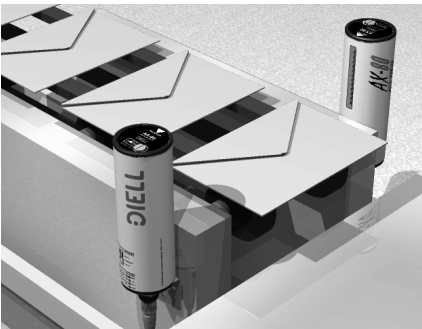

Materials handling: control of envelopes released from conveyors

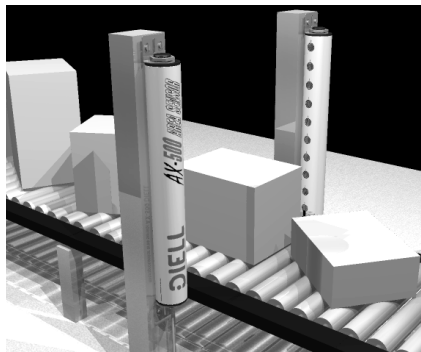

Handling automations: presence detection and height control of objects on conveyors

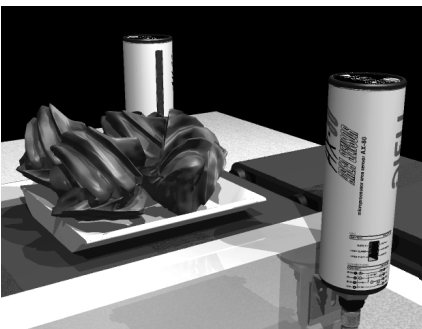

Food packaging: detection of object presence by different and irregular shape



SERIE AX80

**High resolution area sensors
12-24DC**

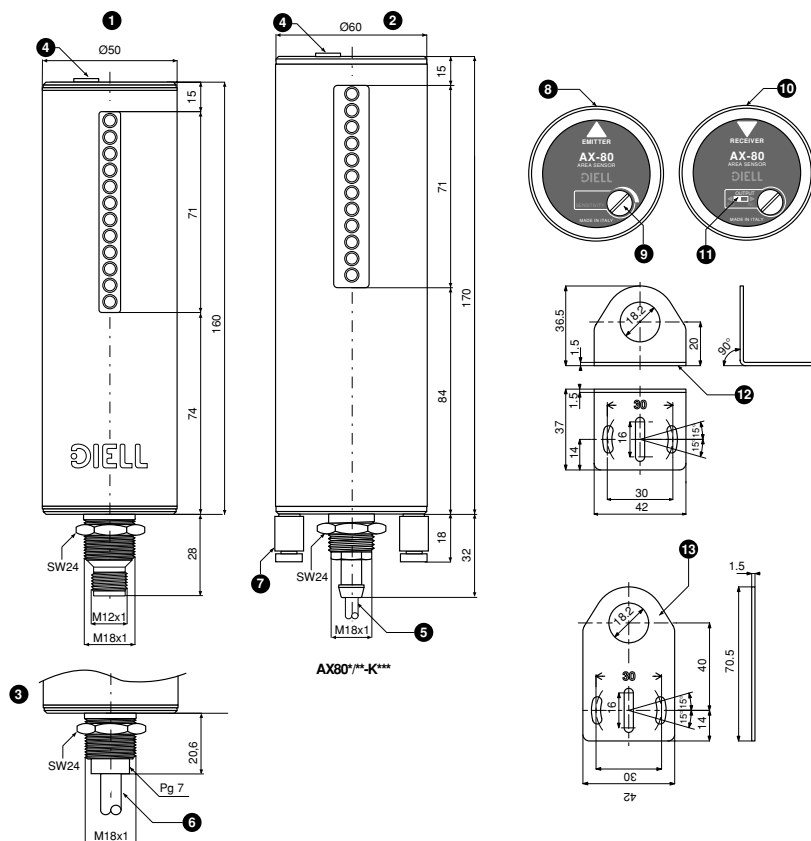
- ◆ Fine detection by 70mm area height
- ◆ Sensing range up to 2m
- ◆ Microcontrolled unit
- ◆ Analogic outputs (4-20mA, 0-10V)
- ◆ Exclusive housing (patented)
- ◆ Very quick fixing by M18x1 standard connection
- ◆ M12 standard connector exit
- ◆ Cable exit for models with analogic outputs
- ◆ Sensitivity adjustment available
- ◆ 3 indicator LEDs on both units
- ◆ Metal housing available for harsh environment applications
- ◆ Timing function available
- ◆ IP65 protection degree
- ◆ Complete protection against electrical damage

DIMENSIONAL DRAWING

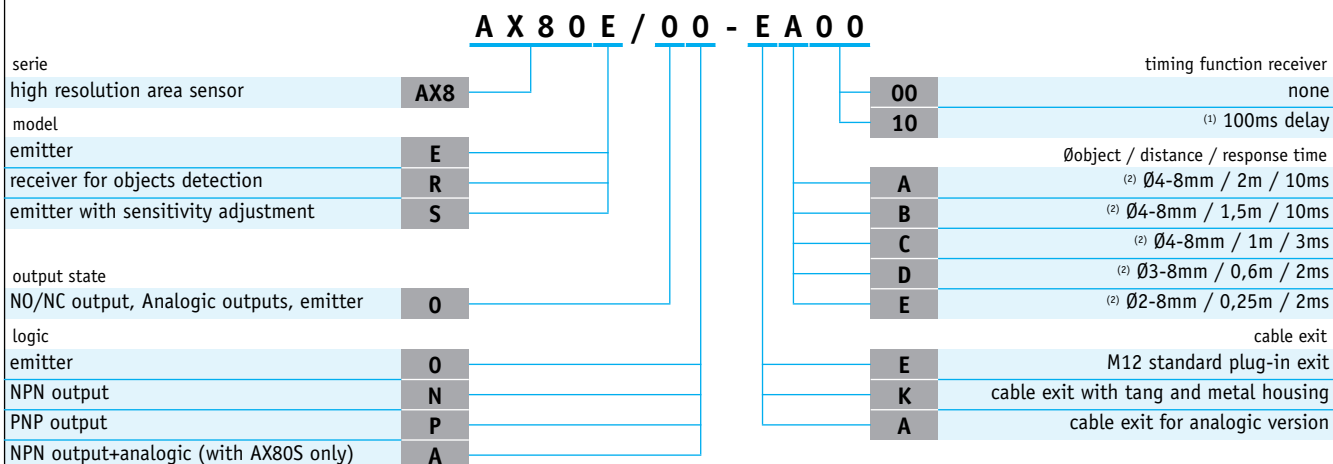
Key

- | | |
|--|--|
| <ul style="list-style-type: none"> 1 M12 plug-in exit (*) 2 Cable exit with tang and metal housing 3 Cable exit for receiver with analogic outputs 4 Protection screw. Remove the screw to reach at the adjustment 5 Cable 4x0,34mm², Ø5mm, PVC, 5m 6 Cable 4x0,34mm²+ 2x0,22mm² shielded, Ø7,5mm, PVC, 5m 7 Pipe connection for air inlet Ø4mm (external) | <ul style="list-style-type: none"> 8 Emitter with sensitivity adjustment AX80S/00-**** 9 Slot for 1 turn trimmer 10 Receiver with NO/NC selectable output 11 Dip-switch slot for NO/NC selection 12 ST 18-C right angle brackets, included 13 ST 18-A axial brackets, included |
|--|--|
- (*) Connectors **CD12L/0B-050A0** included

ORDERING SYSTEM

Note: Models with holes detection function are available

 (1) models with different delays are available on request
 (2) Ø minimum detectable object for models with analogic output is 6-8mm

First example of a new sensor's generation

First example of a new through-beam sensor's generation for the area control. Precise detection of small objects with irregular shapes or unfaced is granted even by random position of the object for a reliable control.
Patented cylindrical housing and M18 standard connection for an incomparable quick installation.

Operation and diagnostic test by microcontroller

Exclusive M18 standard connection

easy mounting like a simple photoelectric sensor

Metal housing

available (cable exit K type) for application in harsh environments

Air pipes for keeping the lenses clean of dust in harsh environments.
Cooling function.

Fine detection by 70mm area height and sensing range up to 2m

AX80 serie generates a **fine grid of 12 beams**, which is able to intercept very small objects (down to a **minimum diameter of 2mm**) by every position within the controlled area.

SPECIFICATIONS					
Model	AX80*/**-*A*0	AX80*/**-*B*0	AX80*/**-*C*0	AX80*/**-*D*0	AX80*/**-*E*0
Nominal sensing distance Sn	2m	1,5m	1m	0,6m	0,25m
Controlled area height	70mm				
Minimum detectable object	Ø4-8mm		Ø3-8mm		Ø2-8mm
Minimum detectable object for analogic outputs	Ø6-8mm, min. Ø holes 25mm (for Z models)				
Emission	infrared (880nm) modulated				
Differential travel	≤10%				
Repeat Accuracy	5%				
Tolerance	0 / 20% of the nominal sensing distance Sn				
Operating voltage	12-24Vdc (standard) - 15-24Vdc (with analogic outputs)				
Ripple	≤10%				
No-load supply current	50mA (receiver) - 100mA (receiver with analogic outputs) - 100mA (emitter)				
Load current	100mA				
Leakage current	≤10µA (at 30Vdc)				
Voltage drop	1,2Vmax. (I _L =100mA)				
Output type	NPN or PNP, NO / NC selectable - NPN + Analogic outputs				
Analogic output (AX80R/OA-A**0 only)	0-10V(in voltage); 4-20mA (in current)				
Excess gain	2 (at the maximum distance)				
Angular displacement	3° (emitter) - 6° (receiver) at the maximum distance				
Response time	10ms	3ms		2ms	
Timing function	fixed (from 0 to 100ms)				
Time delay before availability	500ms				
Supply electrical protections	polarity reversal, transient				
Output electrical protections	short circuit (autoreset)				
Temperature range	0...+50°C (without freeze)				
Temperature drift	10% Sr				
Interference to external light	1500 lux (incandescent lamp), 4500 lux (sunlight)				
Protection degree (DIN 40 050)	IEC IP65				
Emitter's LED indicators	green (supply), red (alarm sync.), yellow (area state)				
Receiver's LED indicators	green (supply), red (alignment), yellow (output state)				
Housing material	PMMA				
Tightening torque	5Nm (plastic nut) - 25Nm (metal nut)				
Weight (approx.)	380g (plastic housing); 650g (metal housing) - 800g, 900g (analogic outputs)				

DIAGNOSTICS

LED	State	Operation	Check
GREEN receiver SUPPLY	stable on unstable on off	Supply is present and stable Supply is present but not stable No supply or voltage lower than 8Vdc	- Supply Supply
RED receiver ALIGNMENT	full on light on off blinking on	No alignment Partial alignment or short signal Correct alignment and sufficient signal Receiver does not function correctly or output short circuit	Alignment * Alignment * - Wiring or failure
YELLOW receiver OUTPUT	on off	Output in ON state Output in OFF state	- -
GREEN emitter SUPPLY	stable on unstable on off	Supply is present and stable Supply is present but not stable No supply or voltage lower than 8Vdc	- Supply Supply
RED emitter SYNC. ALARM	off on	Synchronism property received Synchronism is not received or emitted	- Wiring or failure
YELLOW emitter AREA STATE	on off	Engaged area or uncorrect alignment Free area or correct alignment	Alignment * -

* by free area

3.1

WIRING DIAGRAMS

NPN output		PNP output		Analogic output	
Emitter	Receiver	Emitter	Receiver	Emitter	Receiver
BU/3	BU/3	BN/1	BN/1	BU	BU
BN/1	BN/1	3U/3	BU/3	BN	BN
WH/2	BK/4	3K/4	BK/4	WH	BK
BK/4	WH/2	WH/2	WH/2	BK	WH
					ORG
					GRN

In case of combined load, resistive and capacitive, the max. admissible capacity is 0,2 μF, for max. output voltage and current.

CONNECTORS

M12