

# Serie Heavy

## SR307B Nylon Cable Chain with Aluminium Rods

### Inner height (D) 40 mm

Construction with sidebands male/female joining system with triple nylon pin. Standard chain is equipped with aluminium rods every second pitch; on request rods can be assembled every pitch. Inner width (C) can be supplied with special dimension.

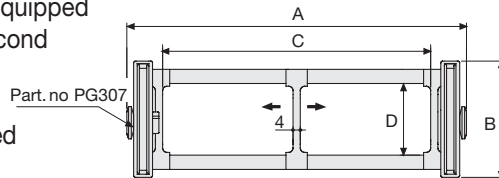

### Separator

- Unassembled	Part. no S307
- Assembled	Part. no S307MC

### Technical characteristics when self-supported

Speed	8 m/s
Acceleration	40 m/s <sup>2</sup>

For higher requirements please consult our technical dept.

3

A	B	C	D	R	Weight/m	Chain
mm	mm	mm	mm	mm	kg	Part Number
117	64	75	40	075-090-120-140-200-250	1,80	SR307B075 □ *
142	64	100	40	075-090-120-140-200-250	1,85	SR307B100 □ *
192	64	150	40	075-090-120-140-200-250	1,95	SR307B150 □ *
242	64	200	40	075-090-120-140-200-250	2,05	SR307B200 □ *
292	64	250	40	075-090-120-140-200-250	2,15	SR307B250 □ *
342	64	300	40	075-090-120-140-200-250	2,25	SR307B300 □ *
C+42	64	.....	40	075-090-120-140-200-250		SR307B □ □ □ □ **

\*Complete the code by inserting the value of the radius (R): Ex. SR306B075 □

Where: 0=90; 1=120; 2=140; 3=200; 4=250; 7=75

\*\*Complete the code by inserting the value of the quote C and the radius (R): Ex. SR307B □ □ □ □ □

Chain equipped with aluminium rods every pitch: complete the code by inserting the letter D. Ex. SR307B0751 □

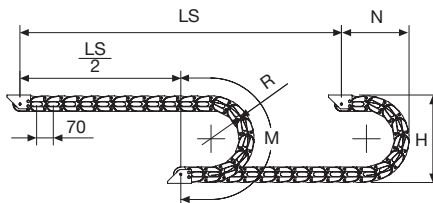

R	H	N	M
mm	mm	mm	mm
075	214	180	375
090	244	195	425
120	304	225	520
140	344	245	580
200	464	305	770
250	564	355	925

Length of chain (L)

Half travel distance ( $\frac{LS}{2}$ )  
plus length of curve (M)

$$L = \frac{LS}{2} + M$$



### Self-Supporting Capacity Diagram

The maximum length of the self-supporting capacity ( $\frac{LS}{2}$ ) in relationship to the weight of the cables and hoses contained per linear metre.

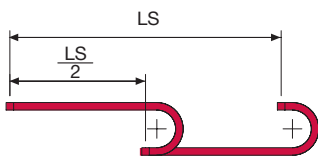
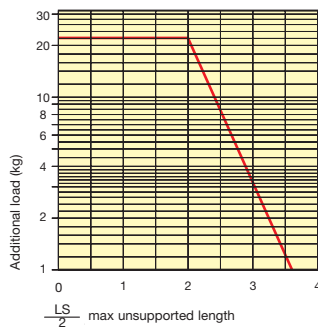

For applications with  $\frac{LS}{2}$  and weights not included in the area of the diagram showing self-supporting capacity, verify the possible use of support rollers (see page 30).

### End Brackets

The end brackets set allows the two ends of the chain to be attached to the equipment.

#### Nylon Type

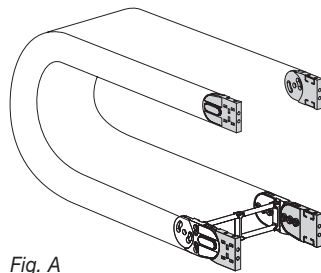

Fig. A

End brackets can be mounted in any position. (Fig. A)

#### Bright Zinc Plated Steel Type\*

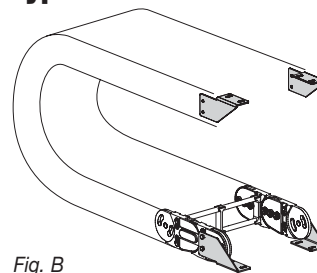
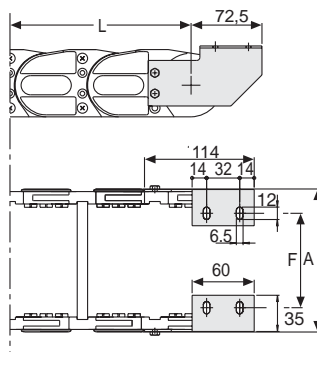
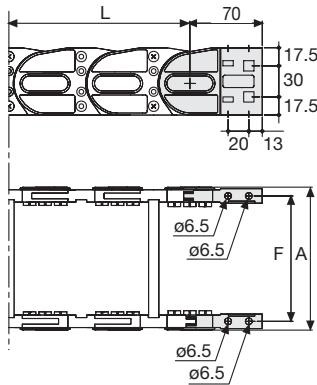

Fig. B

Chain fixed outside the radius. (Fig. B) See end brackets mounting variations: page 31.



Chain	F
	mm
SR307B075	98
SR307B100	123
SR307B150	173
SR307B200	223
SR307B250	273
SR307B300	323

Special dimension F=A-19

Chain	F
	mm
SR307B075	68
SR307B100	93
SR307B150	143
SR307B200	193
SR307B250	243
SR307B300	293

Special dimension F=A-49

### Nylon Type Part Numbers

#### Complete Set Assembled

Chain Type	End Brackets Set
SR307B...	AN307KM

#### Complete Set Unassembled

SR307B...	AN307K
-----------	--------

### Bright Zinc Plated Steel Type Part Numbers

#### Complete Set Assembled

Chain Type	End Brackets Set
SR307B...	A307KM □**

#### Complete Set Unassembled

SR307B...	A307K □**
-----------	-----------

\*Available on request in stainless steel

\*\* 1=pos. 1; 2=pos.2; 3=pos.3

See end brackets mounting variations page 31.

## Serie Heavy

# SR307B

Nylon Cable Chain with Aluminium Rods

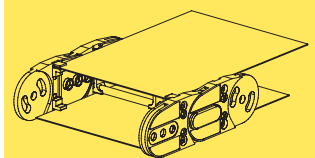

Steel laminar cover.

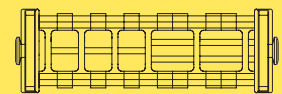

Supplementary movable separators.

Special tool to remove the connecting pivots: part number PZ036.

For further information please consult Brevetti Stendalto's Technical Office