

Serie Heavy

SR306B Nylon Cable Chain with Aluminium Rods

Inner height (D) 30 mm

Construction with sidebands male/female joining system with triple nylon pin. Standard chain is equipped with aluminium rods every second pitch; on request they can be assembled every pitch. Inner width (C) can be supplied with special dimension.

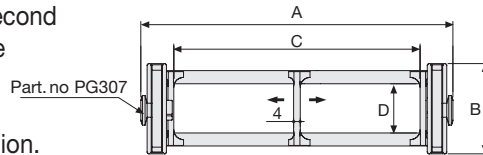

Separator

- Unassembled	Part. no S2000F
- Assembled	Part. no S2000FMC

Technical characteristics when self-supported

Speed	8 m/s
Acceleration	40 m/s ²

For higher requirements please consult our technical dept.

3

A	B	C	D	R	Weight/m	Chain
mm	mm	mm	mm	mm	kg	Part Number
115	55	75	30	075-107-150-200-250-300	1,60	SR306B075 □ *
140	55	100	30	075-107-150-200-250-300	1,65	SR306B100 □ *
190	55	150	30	075-107-150-200-250-300	1,80	SR306B150 □ *
240	55	200	30	075-107-150-200-250-300	1,90	SR306B200 □ *
290	55	250	30	075-107-150-200-250-300	2,00	SR306B250 □ *
340	55	300	30	075-107-150-200-250-300	2,15	SR306B300 □ *
C+40	55	30	075-107-150-200-250-300		SR306B □ □ □ □ **

*Complete the code by inserting the value of the radius (R): Ex. SR306B075 □

Where: 1=075; 2=107; 3=150; 4=200; 5=250; 6=300

**Complete the code by inserting the value of the quote C and the radius (R): Ex. SR306B □ □ □ □ □

Chain equipped with aluminium rods every pitch: complete the code by inserting the letter D.

Ex. SR306B0751 □

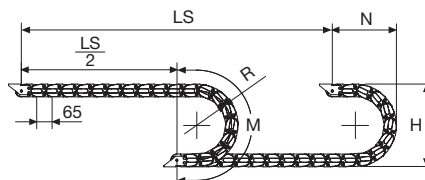

R	H	N	M
mm	mm	mm	mm
075	205	170	370
107	269	205	470
150	355	245	605
200	455	295	760
250	555	345	920
300	655	395	1075

Length of chain (L)

Half travel distance ($\frac{LS}{2}$)
plus length of curve (M)

$$L = \frac{LS}{2} + M$$



Self-Supporting Capacity Diagram

The maximum length of the self-supporting capacity ($\frac{LS}{2}$) in relationship to the weight of the cables and hoses contained per linear metre.

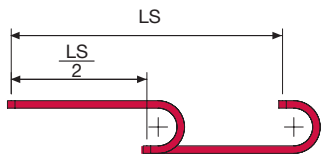
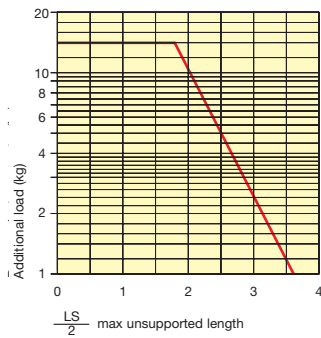

For applications with $\frac{LS}{2}$ and weights not included in the area of the diagram showing self-supporting capacity, verify the possible use of support rollers (see page 30).

End Brackets

The end brackets set allows the two ends of the chain to be attached to the equipment.

Nylon Type

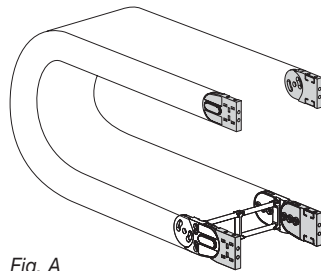

Fig. A

End brackets can be mounted in any position. (Fig. A)

Bright Zinc Plated Steel Type*

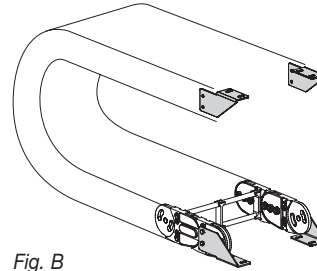
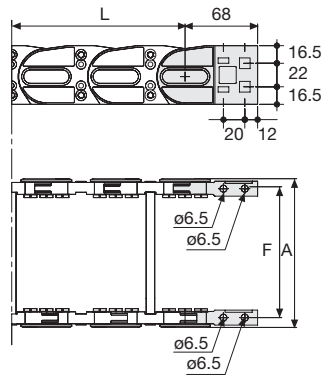

Fig. B

Chain fixed outside the radius. (Fig. B) See end brackets mounting variations: page 31.



Chain	F
	mm
SR306B075	96
SR306B100	121
SR306B150	171
SR306B200	221
SR306B250	271
SR306B300	321

Special dimension F=A-19

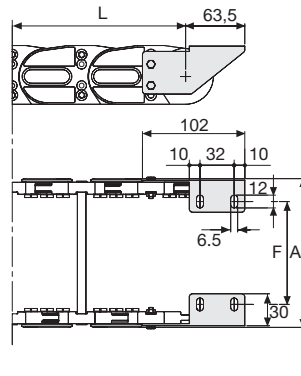

Chain	F
	mm
SR306B075	71
SR306B100	96
SR306B150	146
SR306B200	196
SR306B250	246
SR306B300	296

Special dimension F=A-44

Nylon Type Part Numbers

Complete Set Assembled

Chain Type	End Brackets Set
SR306B...	AN306KM

Complete Set Unassembled

SR306B...	AN306K
-----------	--------

Bright Zinc Plated Steel Type Part Numbers

Complete Set Assembled

Chain Type	End Brackets Set
SR306B...	A306KM □**

Complete Set Unassembled

SR306B...	A306K □**
-----------	-----------

*Available on request in stainless steel

** 1=pos. 1; 2=pos.2; 3=pos.3

See end brackets mounting variations page 31.

Serie Heavy

SR306B

Nylon Cable Chain with Aluminium Rods

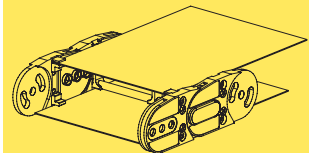

Steel laminar cover.

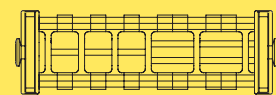

Supplementary movable separators.

Special tool to remove the connecting pivots: part number PZ036.

For further information please consult Brevetti Stendalto's Technical Office